

UPGRADE YOUR SYSTEM



COMMAND-10® REMOTE

- Remote and receiver come pre-programmed and easy to re-program
- Remote controls 10 devices from more than 100 ft. away or from the comfort of your cab
- Remote shuts off when the lid is closed or after 3 minutes of inactivity
- Built-in overload protection
- Stainless steel terminals and hardware

ROLTEC™ ELECTRIC HOPPER CONVERSION

- Worm gear motor and chain drive gear box provide optimal torque needed to open and close the hopper
- Worm gears create an instant, positive lock
- Stainless steel housing and sprocket with nickel plated chain are durable and resistant to corrosion
- Three point, high clearance mounting design
- Split sprocket technology
- Manual override if needed

Command Station available

ORDER NOW

Measure your equipment to start your order process:

Equipment Type: _____

A. Upper Box Length: _____

B. Upper Box Width: _____

C. Box Height (from ground): _____

Fabric Color: _____

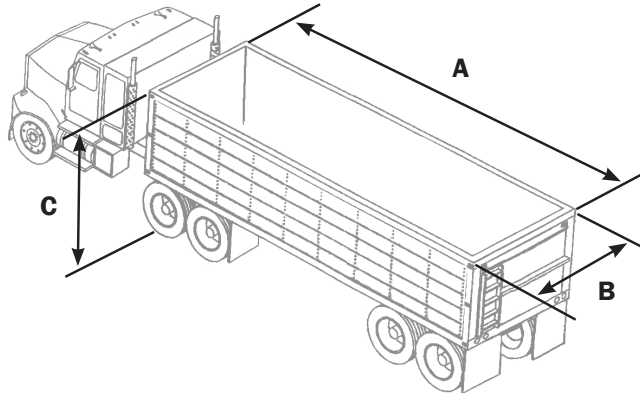

AGRICOVER.COM

© 2016 AGRI-COVER, INC. ALL RIGHTS RESERVED.

Distributed By:



Billings, MT
Hastings, NE
Valley City, ND
Yakima, WA
Phone: 800-437-9702
Fax: 800-313-3299
www.feinc.com

60827_E

122915



No arm to obstruct
the back of trailer

**Our premium electric solution
for semi and grain trailers**

American Made
Tested. Trusted. Guaranteed.

AUTOLOCK® ELECTRIC TARP

ROLL IN THE WIND WITH CONFIDENCE!



MOTOR

- Worm gears create an instant, positive lock
- No brakes to fail
- Chain drive has a powerful and fast 194:1 gear ratio
- Stainless steel housing and sprocket with nickel plated chain are durable and resistant to corrosion

UNIQUE DUAL DRIVE™ SYSTEM

- Wind resistant design featuring a strong synthetic cable and tension spring that work together to provide a powerful front and rear drive to cover your load

ROTATING AND TELESCOPING MOTOR MOUNT

- Allows roll tube to rise and flex over heaped loads, reducing stress on the drive components and pivot arm

EXTRA DURABLE 3" ALUMINUM ROLL TUBE

- Strong, yet lightweight offers a faster and straighter roll
- Rope channel is a continuous tarp attachment creating uniform tension for a better fitting and longer lasting tarp

CUSTOM END CAPS*

- Low profile wind deflector is hand and tarp friendly
- Crimped standing seam is self sealing, flexible with no welds to break
- Integrated weather sealing rib

QUICK RELEASE ALUMINUM TARP STOPS*

- Integrated set screw on front and rear to eliminate tube sliding
- Open pin channel prevents seizing up
- No brittle die cast metal to break off and tear the tarp
- Opens and closes freely for easy removal

TARP CONSTRUCTION

- Welded 12" reinforced ends
- Webbing reinforcements for added strength
- Premium commercial grade, UV resistant 18 and 22 oz. vinyl fabric remains flexible at -40°

NO ARM TO OBSTRUCT THE BACK OF TRAILER

- Great for chip and refuse trailers as well as end dumps and rear conveyors

OPTIONS

- Manual override kit available Part # 70090

FASTENERS*

*Available in stainless steel